

WATERMAN 21C115 N.O. SOLENOID VALVE
 TORQUE TO 475 IN-LBS (40 FT-LBS)
 704028-12 12VDC SPADE TERMINAL COIL

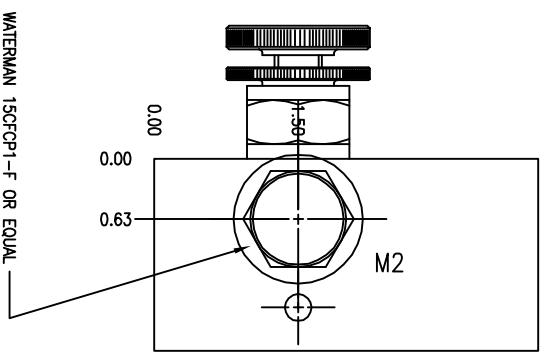
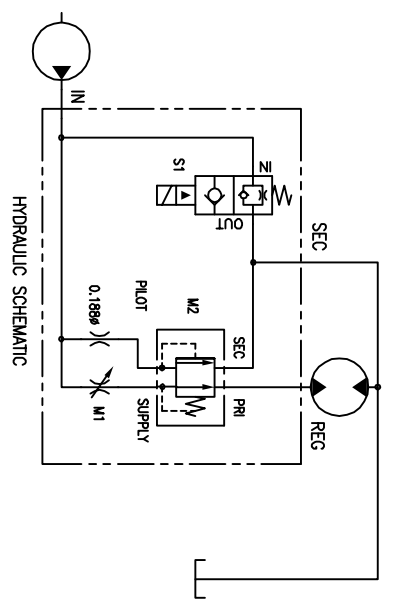
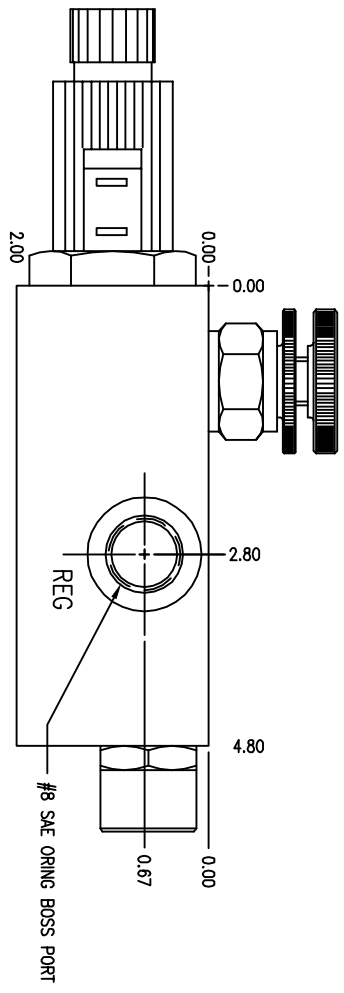
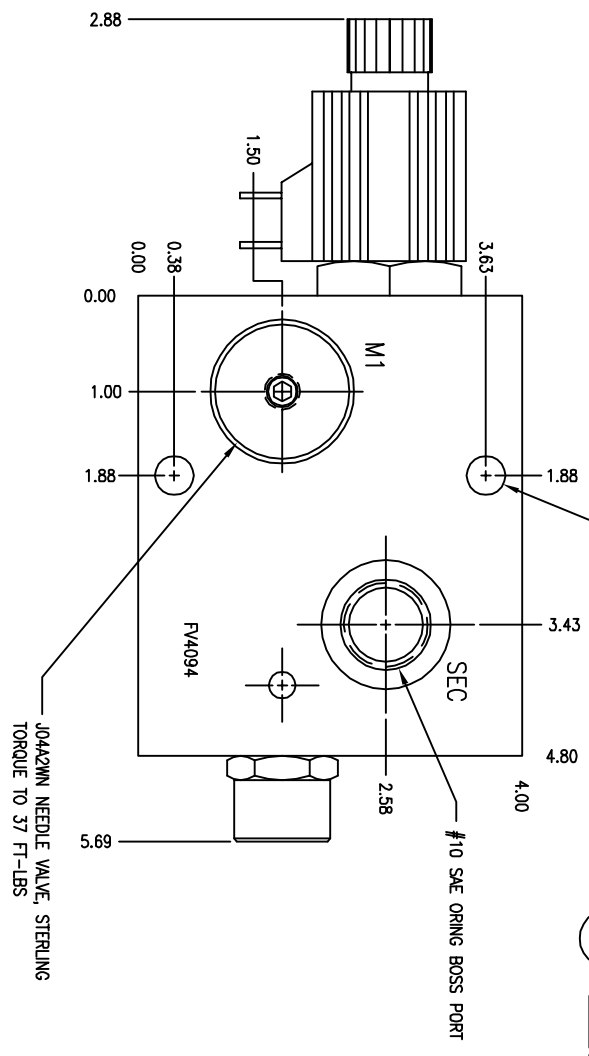
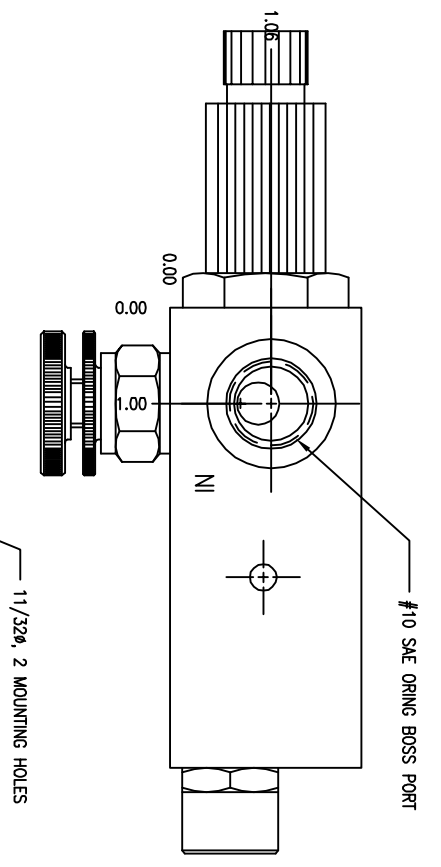
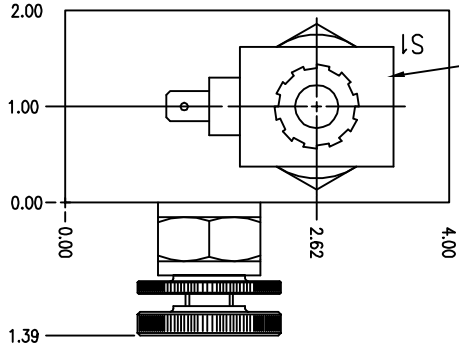

WATERMAN 15GFCP1-F OR EQUAL
 TORQUE TO 190 IN-LBS
 PRESSURE COMPENSATING ELEMENT
 ORIFICE ACCESS UNDER CARTRIDGE